

The company:



Avermann group

Founded in 1946, still remains a family business with head office in Osnabrück

approx. 300 employees on location in Osnabrück, Erfurt, Hungary and Poland

Fields of expertise: Equipment for precast concrete factories as well as waste management and recycling technology

Partner of many well-known national and international companies (STRABAG, IKEA...)

Product range:

Avermann Maschinenfabrik Osnabrück

Equipment for precast industry

Tilting table production

Vibration line production

Forms

Special machinery

Pallet rotation plant production

Plant components

Waste management/recycling

Mobile waste compactors

Stationary compactors

Screw compressors

Drum presses

Horizontal baling presses

Sorting plants and technology

Drum screens

Head Quarter Osnabrück:

Avermann Maschinenfabrik

Equipment for precast industry

Waste management/recycling

Development / design

Planning

Production of machines and plants

Assembly and commissioning

After Sales Service

Services:

Equipment for precast concrete factories

Planning

Development

Design

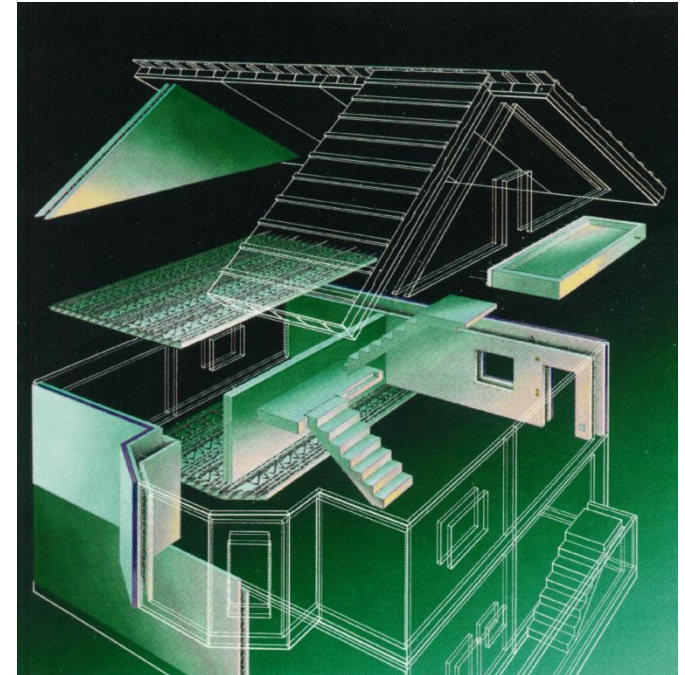

Example concrete formwork



Twin-beam form



Example concrete formwork



Stairform

Example tilting table production

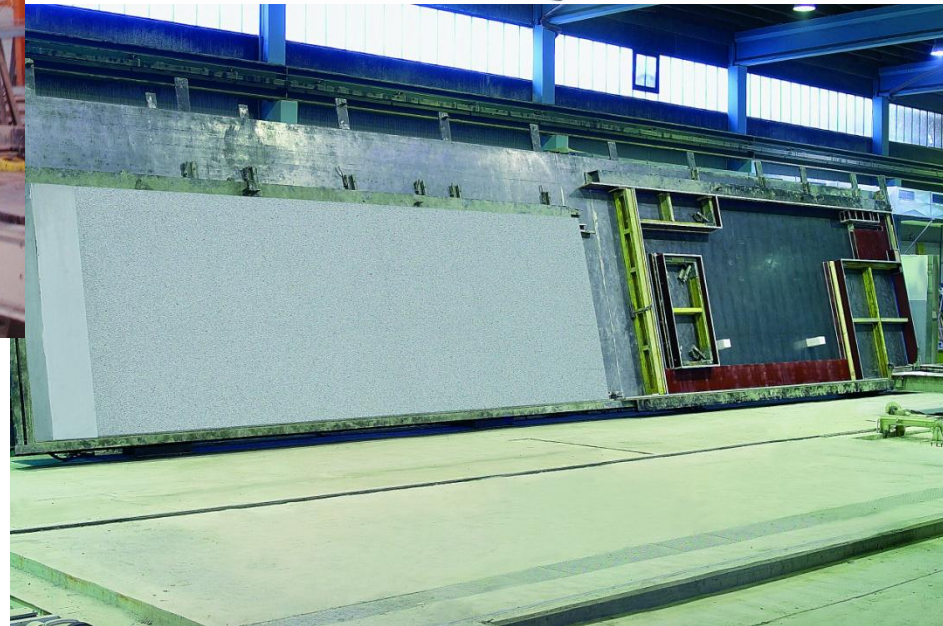

Tilting tables with AV vibration technology

Example special machinery



Concrete distributor connected to crane

Example special machinery

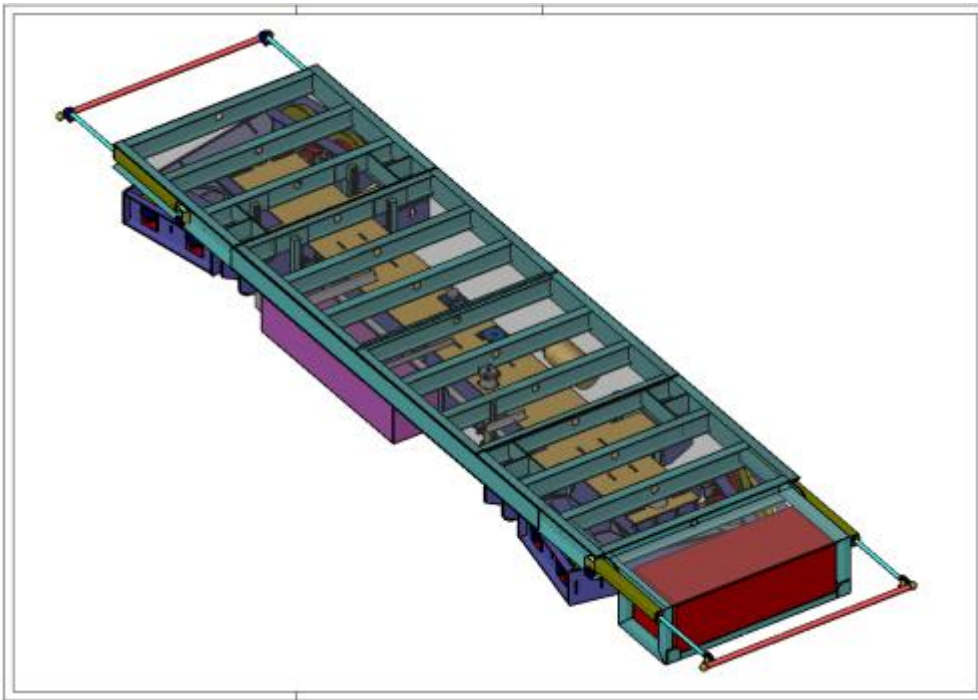

Element transportation

Example special machinery

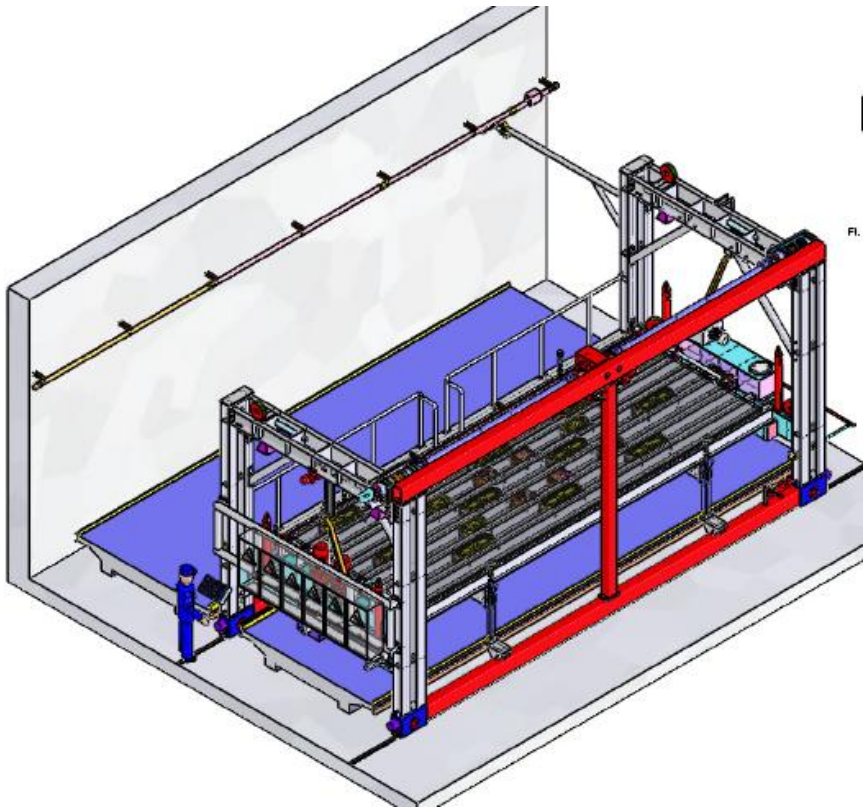

Turning device with vacuum technology



Example special machinery



Rack feeder (overhead)

Example special machinery

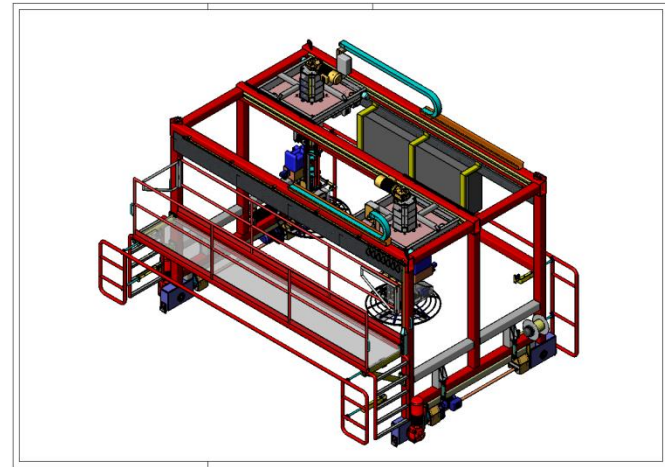

Smoothing device (power trowel)



Example circulating



Circulation system for solid wall production

Example circulating

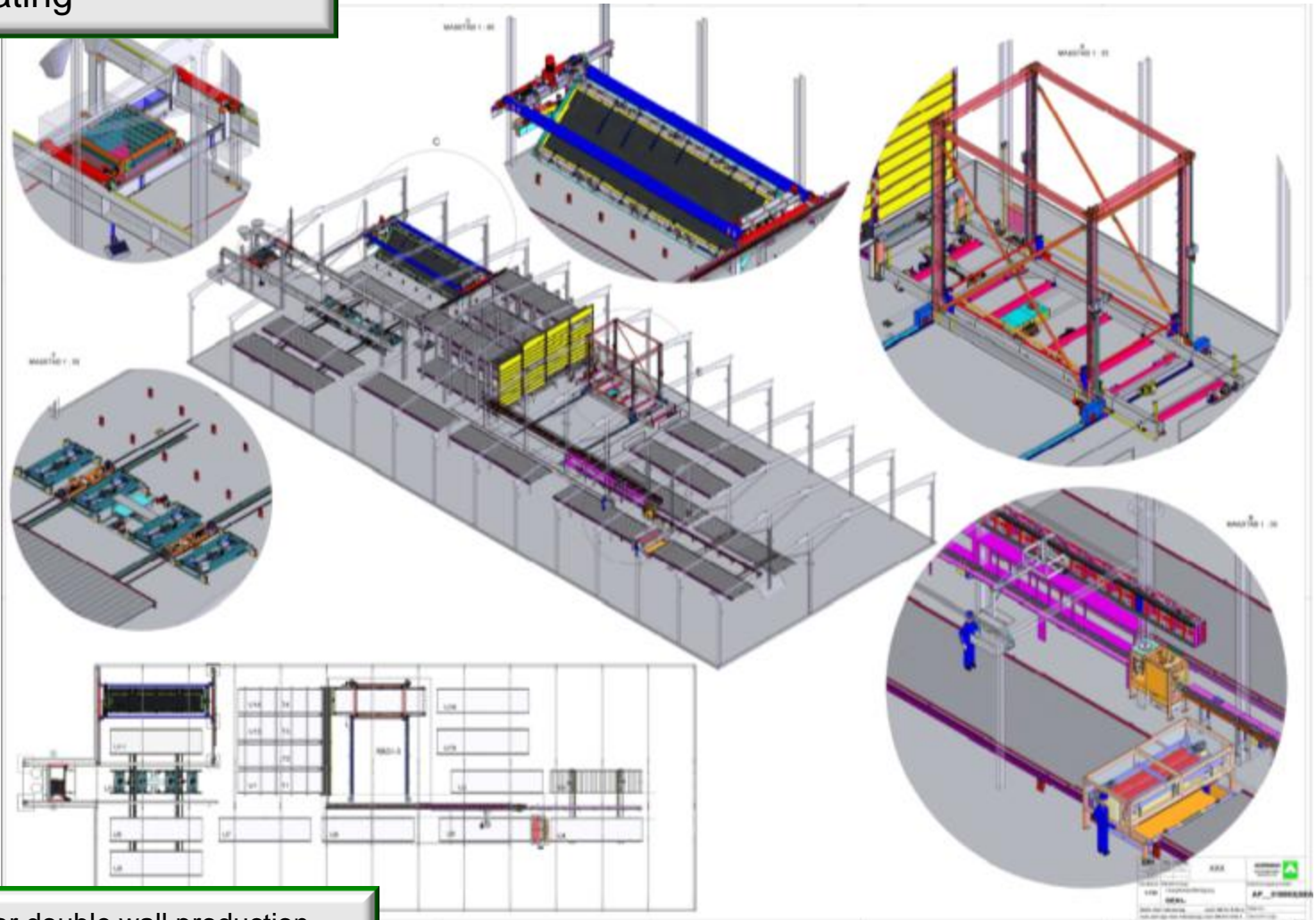

Circulation system for double wall production

Examples for concrete product range



Wall and facade elements



Examples for concrete product range



Three-dimensional blocks and structural concrete



Range of services:

We take on project responsibility for

Engineering

Project management & implementation

International service & support

We offer competence through

International project experience

Qualified employees

Coordinated products

Ongoing development

AVERMANN

References

