

AZO – Ingredient automation for the building industry

Right to the point

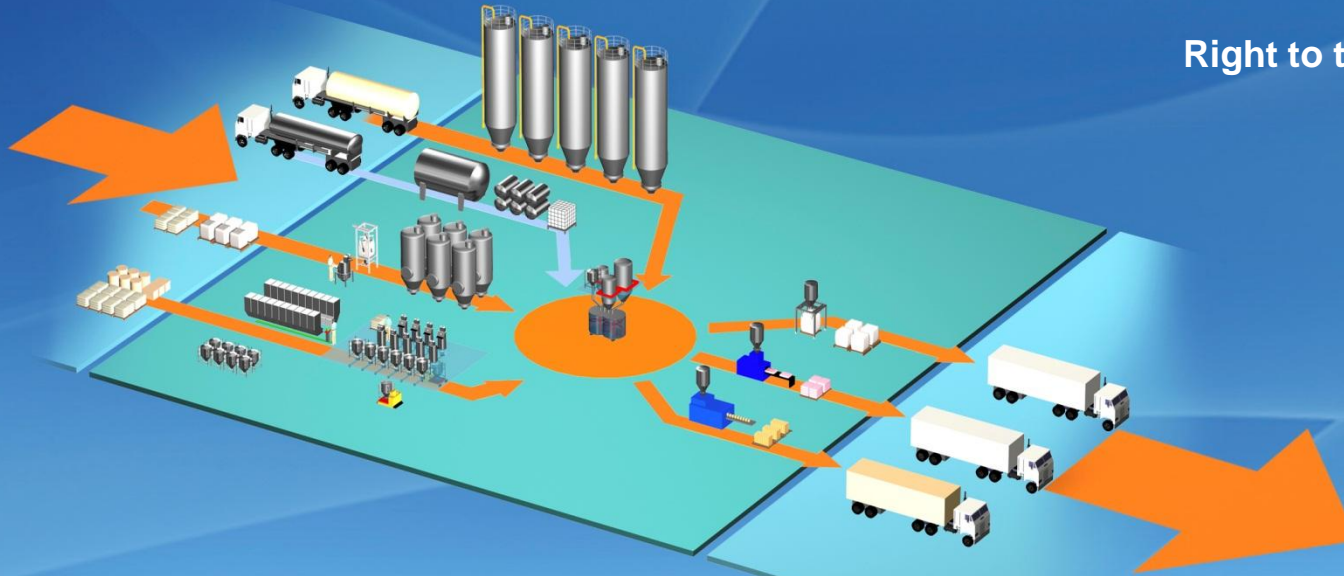

Ingredient automation is our world

Welcome to AZO SOLIDS



AZO<sup>®</sup> Chem



Family-owned company in the third generation  
from left: Robert Zimmermann, Denise Zimmermann, Rainer Zimmermann and founder Adolf Zimmermann

**AZO GmbH + Co. KG**  
Managing Directors:  
Robert Zimmermann  
Rainer Zimmermann

Founded: 12.05.1949 by Adolf and Marianne Zimmermann  
Turnover 2013: 165 Mio. EURO  
Staff: 975 worldwide, including 34 trainees

Total area: 68.500 m<sup>2</sup>  
Covered with buildings: 32.500 m<sup>2</sup>  
laying of the foundation stone: 1963

## Staff 2013 AZO Group

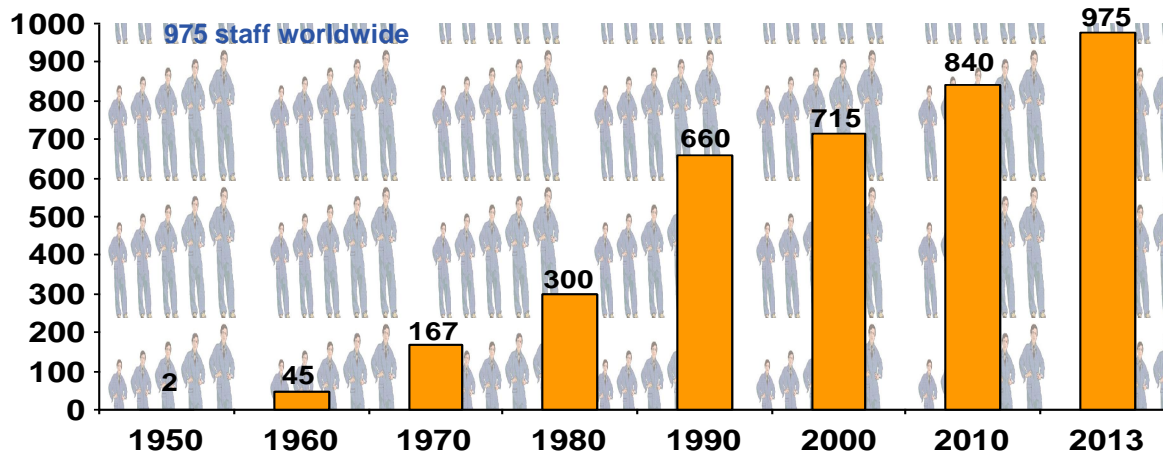

## Turnover 2013 AZO Group

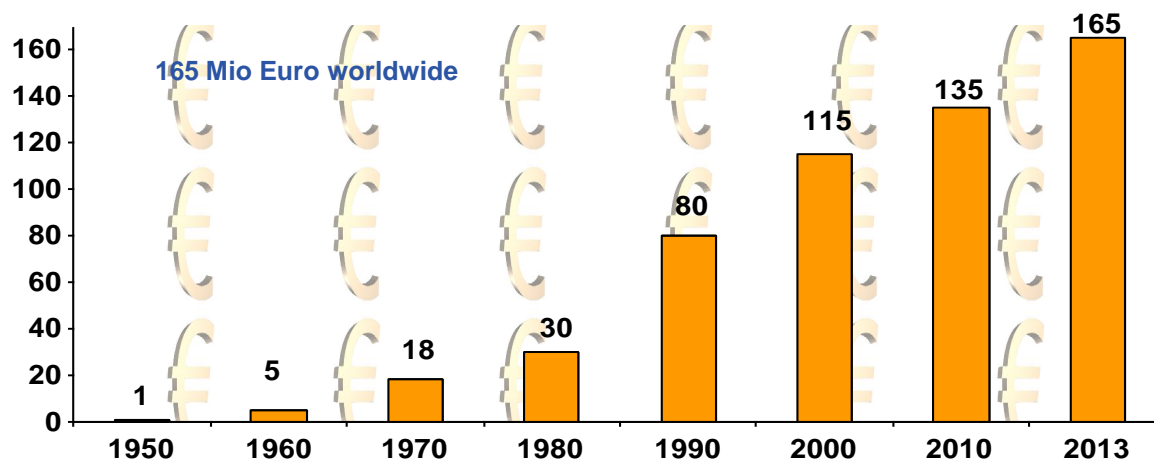





**AZO North America**  
1978  
Memphis, USA  
Sales, Engineering,  
After Sales



**AZO United Kingdom** 2006  
Burton-upon-Trent,  
Great Britain  
Sales



**AZO Benelux** 1995  
Antwerpen,  
Belgium  
Sales, Engineering,  
After Sales



**AZO France** 1998  
La Haye  
Fouassiere, France  
Sales, Engineering,  
After Sales



**AZO Russia** 2013  
Moskau, Russia  
Sales, After Sales



**AZO China** 2007  
Tianjin, China  
Sales, After Sales



**AZO ASEAN 2006, Bangkok, Thailand**

- Sales
- Process Engineering
- Engineering
- Installation, Commissioning and After Sales
- 26 staff speaking 7 languages

### Supply of raw material

silo vehicle • tank truck  
big bags • sacks • container drums  
• cartons

### Value-added process

mixing • kneading • stirring • milling  
extrusion • dispersing • cooling  
drying • granulation

### Delivery of finished and semi-finished products

filling • packing

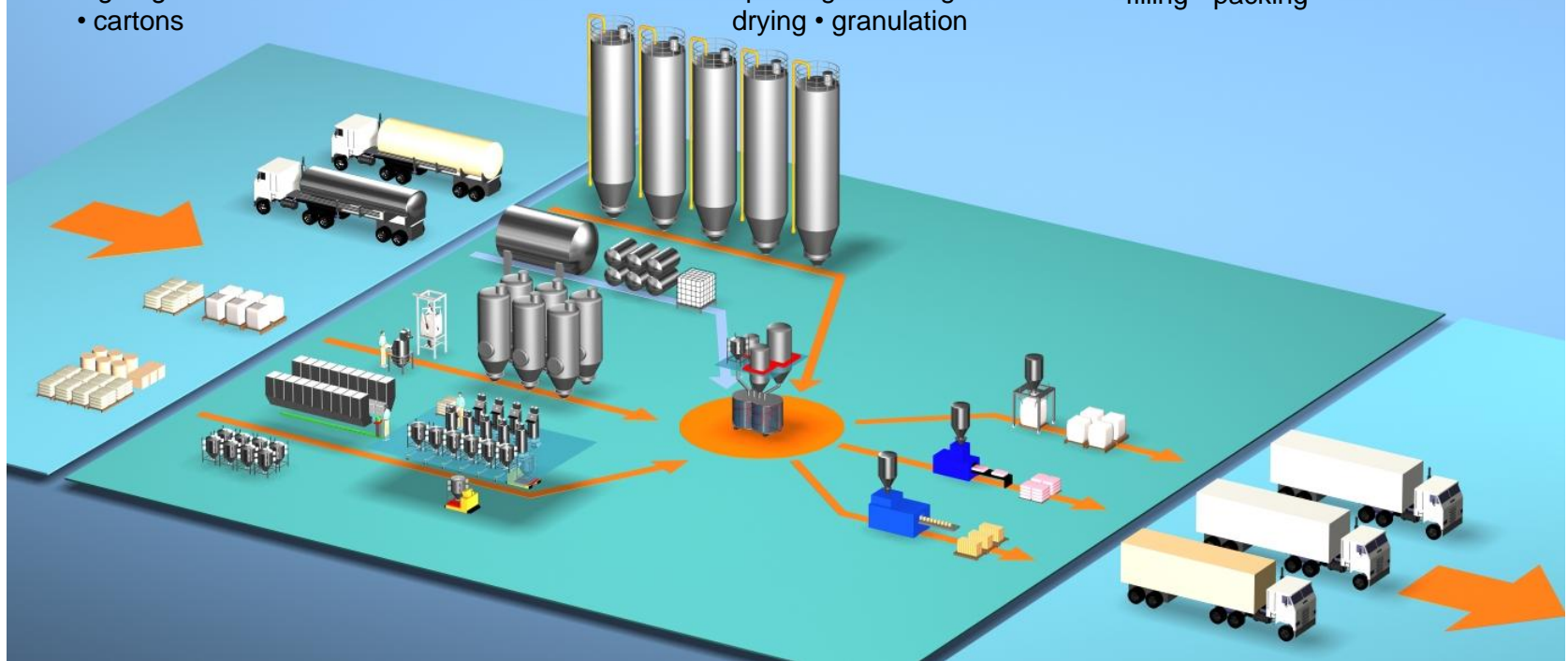

Storing  
Discharging

Feeding  
Screening

Conveying  
Feeding

Dosing  
Weighing

Operating  
Controlling

Monitoring  
Documentation



**Research and Development**  
50 Technicians and Engineers



**AZO CONTROLS**  
150 Employees



**AZO LIQUIDS**  
40 Employees



**Advice / Design / Development**  
180 Technicians and Engineers



**Education and Advanced training**  
32 Trainees / 30 course / year 420 participants



**Production with high vertical integration**  
200 Employees



**Service / Assembly / Commissioning**  
30 Employees





# System example





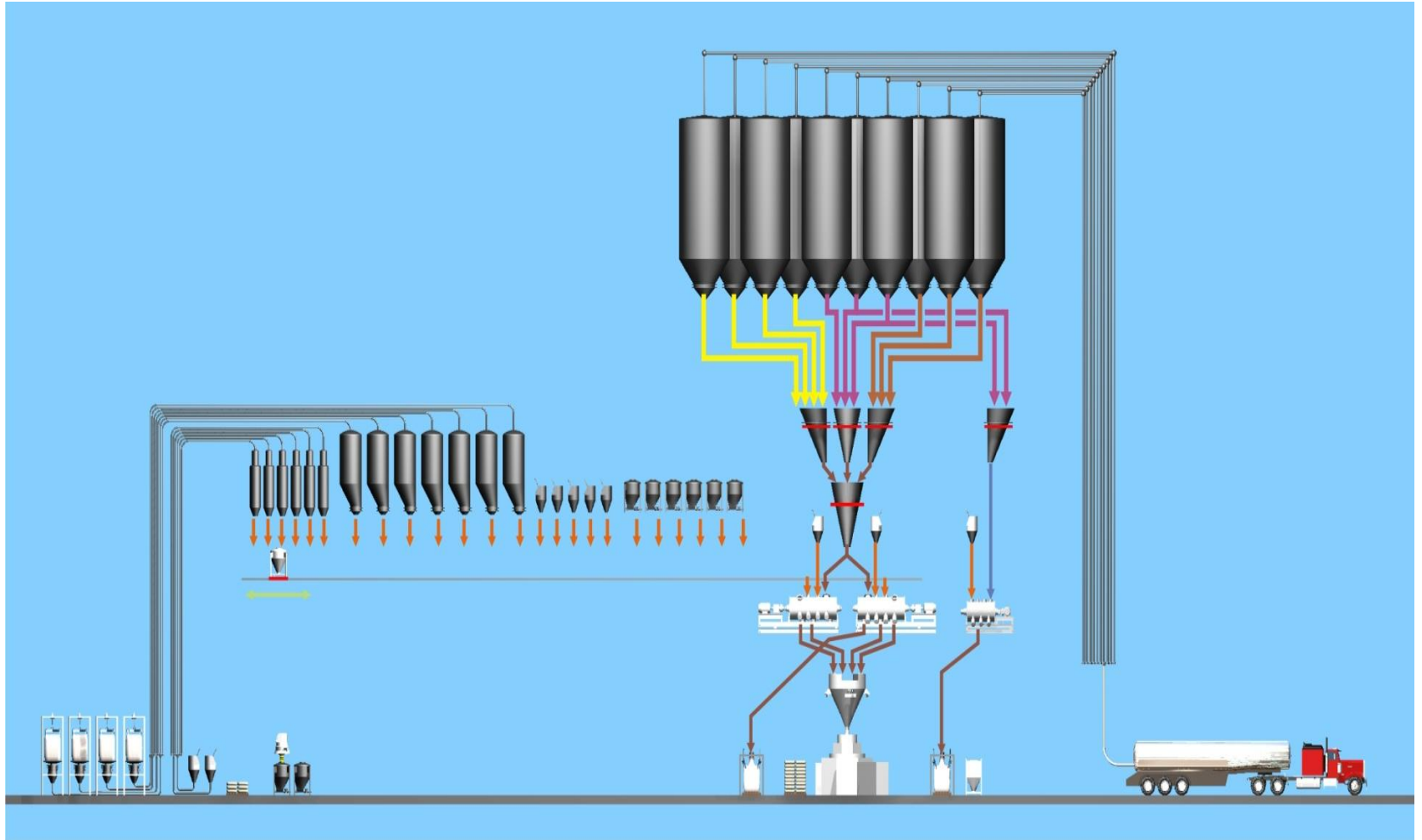

Storage of major ingredients



Outdoor silo with filling lines and filters



Special design of pipe bends for wear reduction

Discharge and dosing of product



Dosing screws with screeners below



Dosing screw with fine dosing



Weighing of major ingredients in hopper scales



Hopper scales with 3-point weighing unit

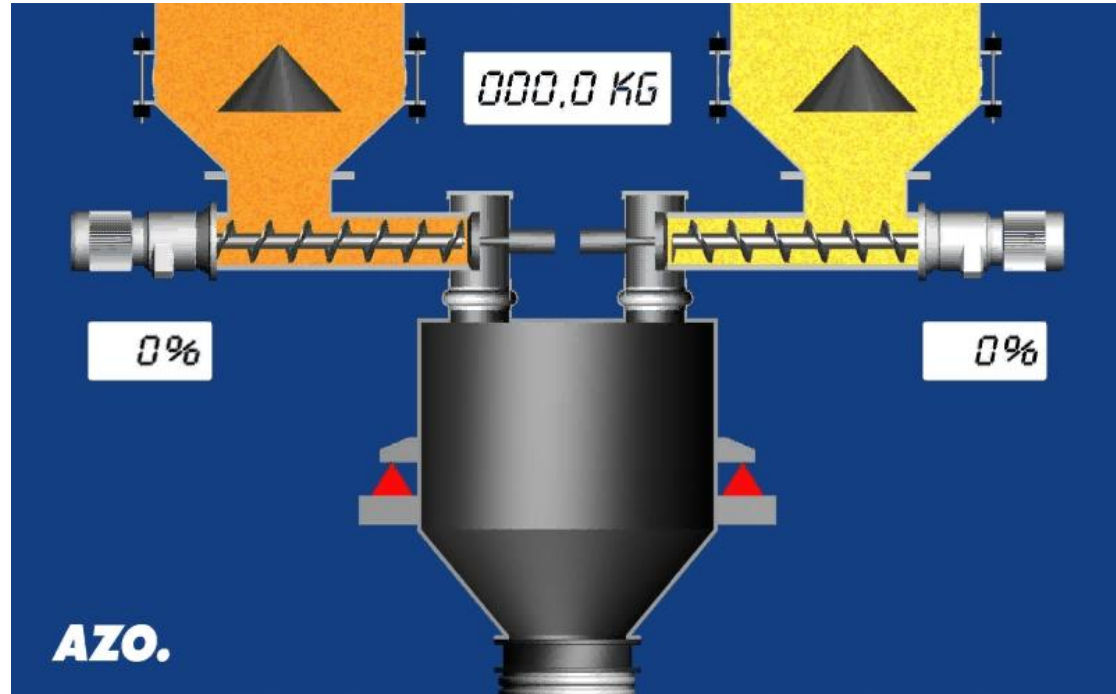

Product feeding of minor ingredients



Feeding hopper with central aspiration

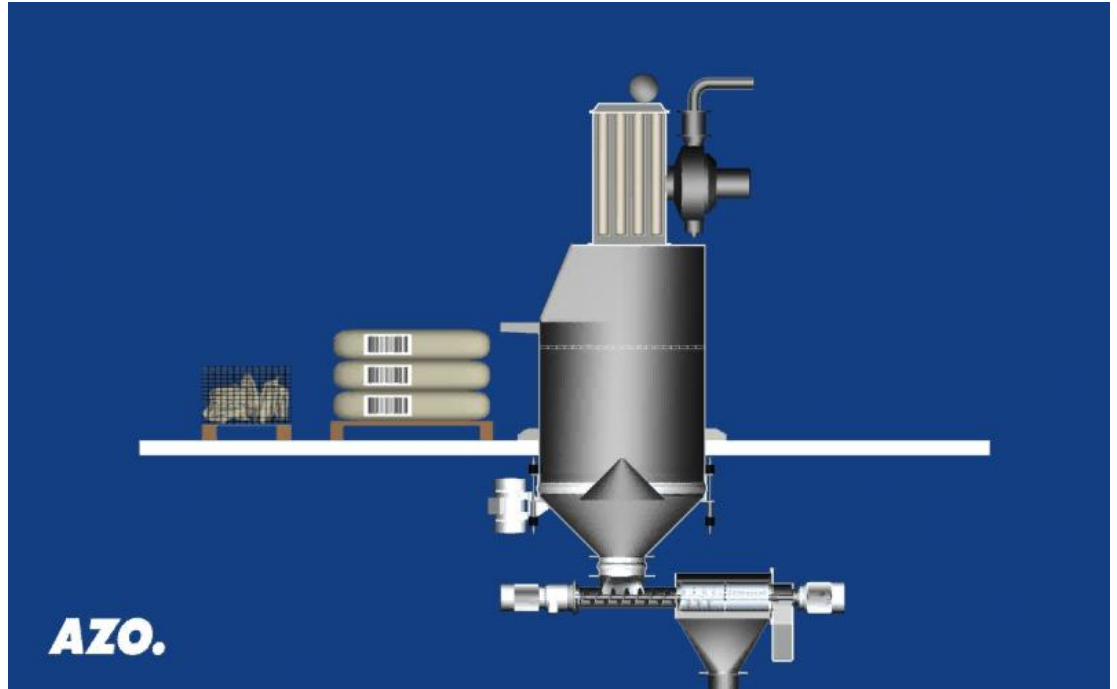

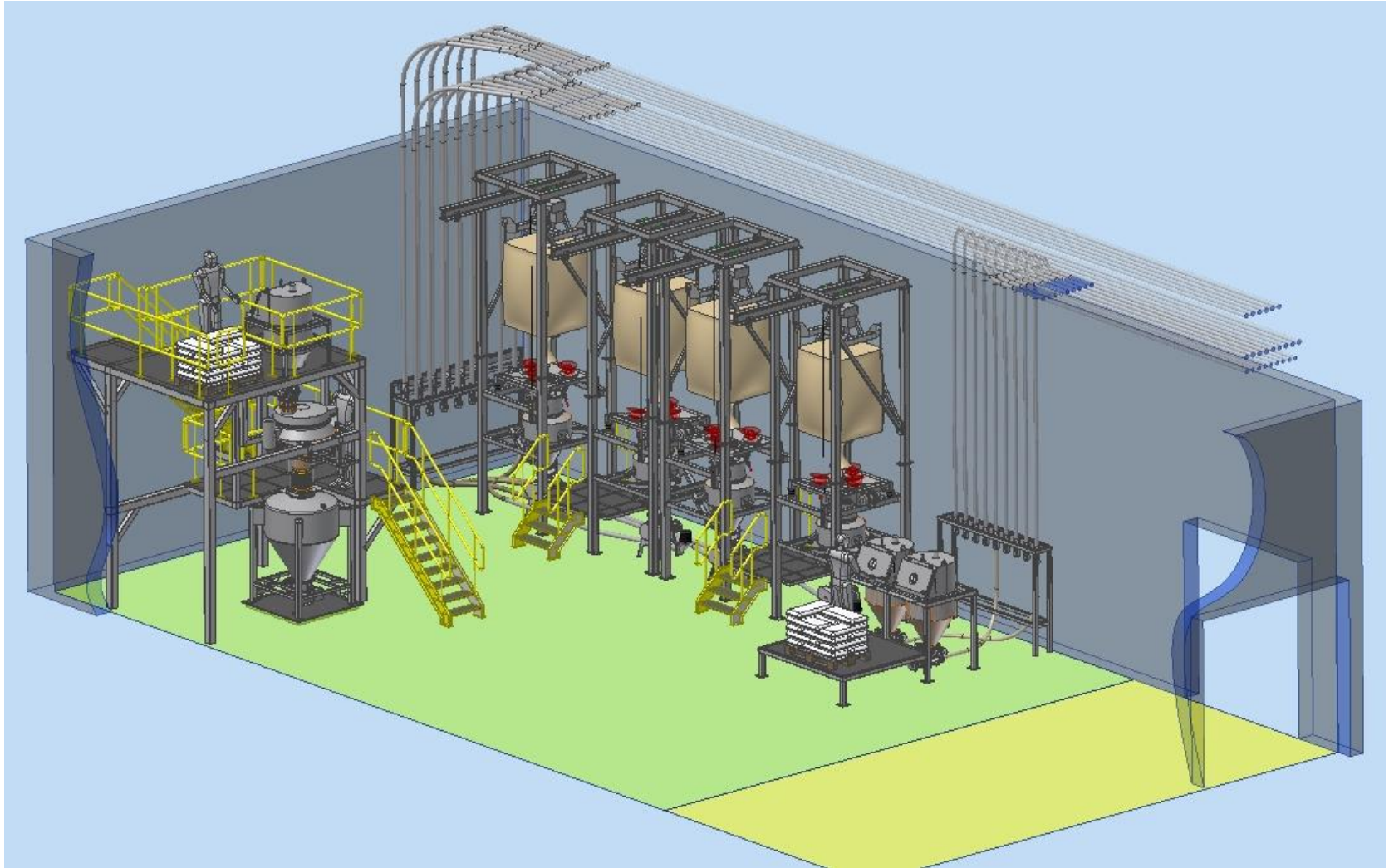



Product feeding of medium ingredients



Big bag emptying stations

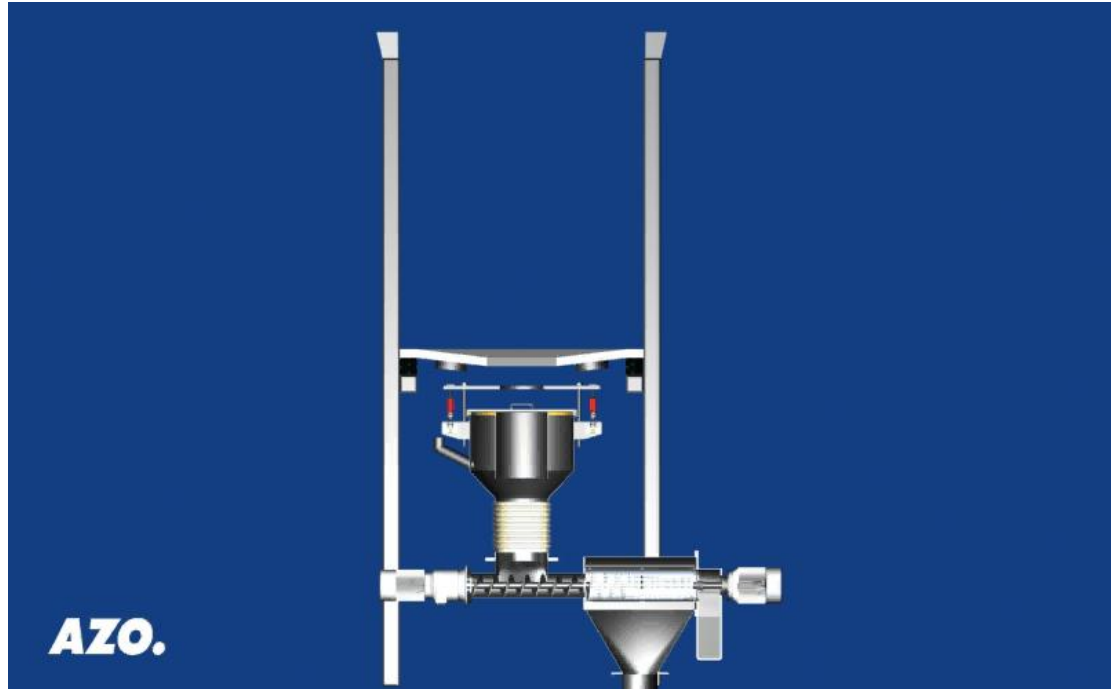

Control screening of products



Cyclone screener

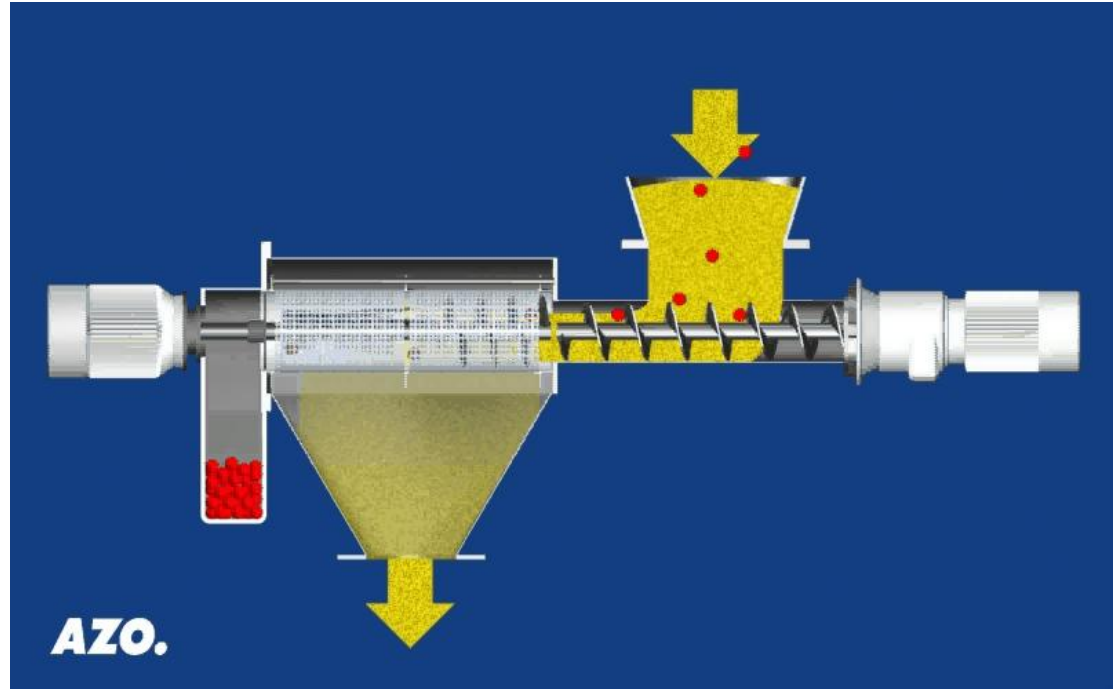

Vacuum conveying system for medium ingredients



Buffer bins for temporary storage of products

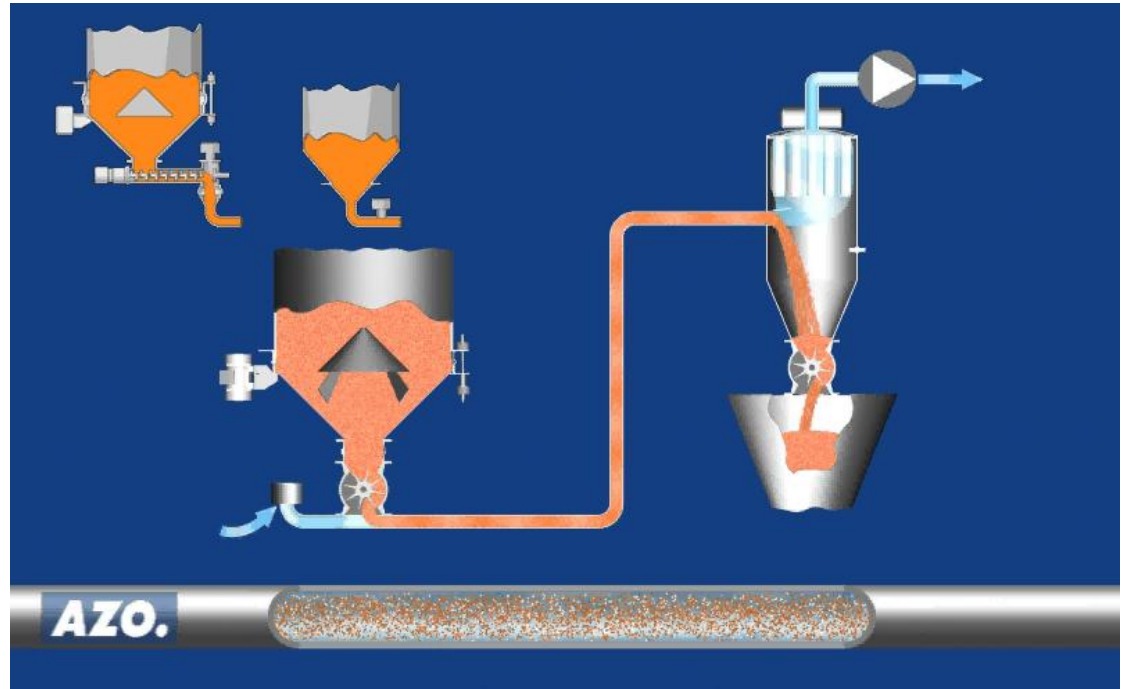



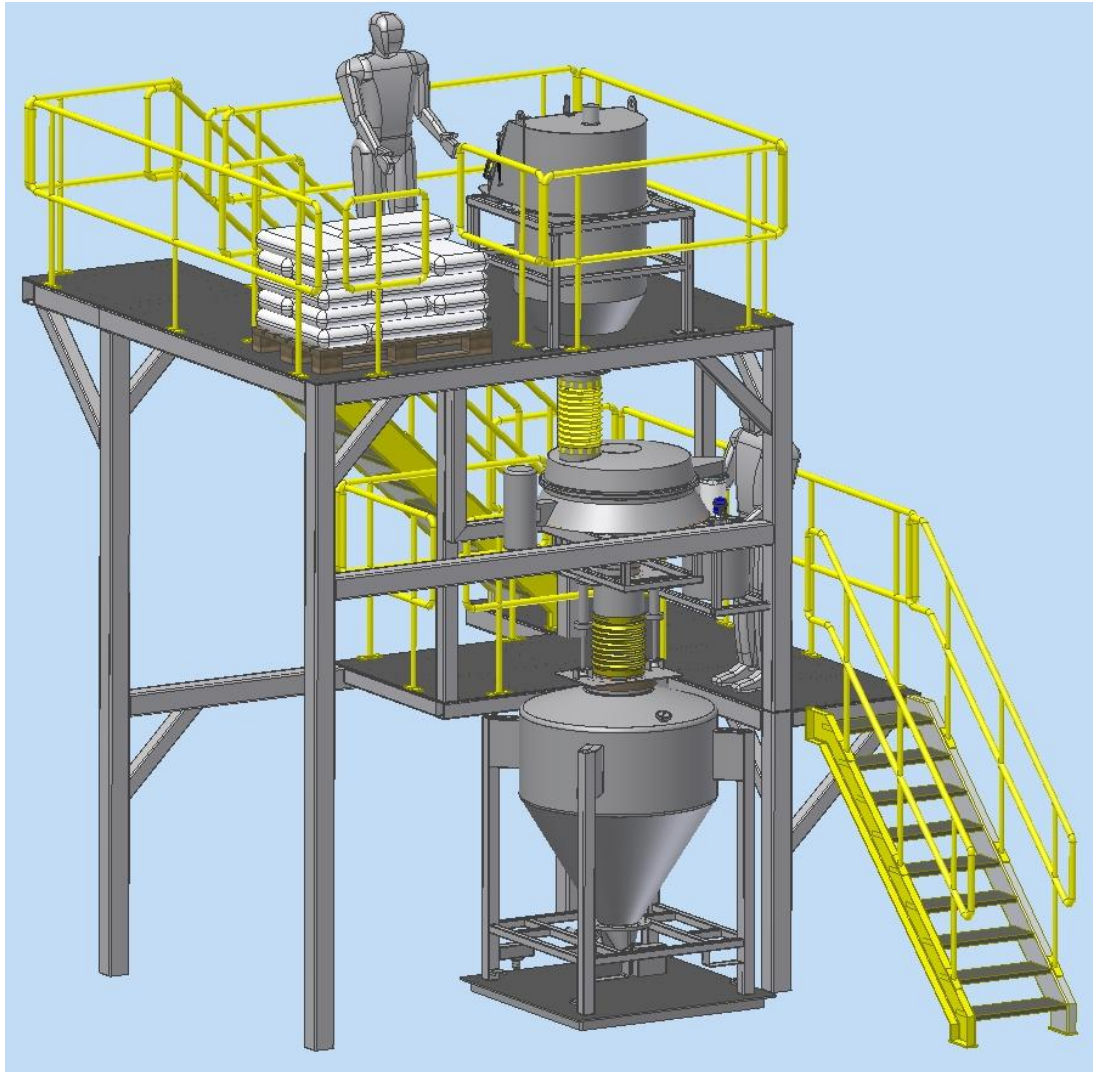

Filling of DOSITAINERS® with bagged goods

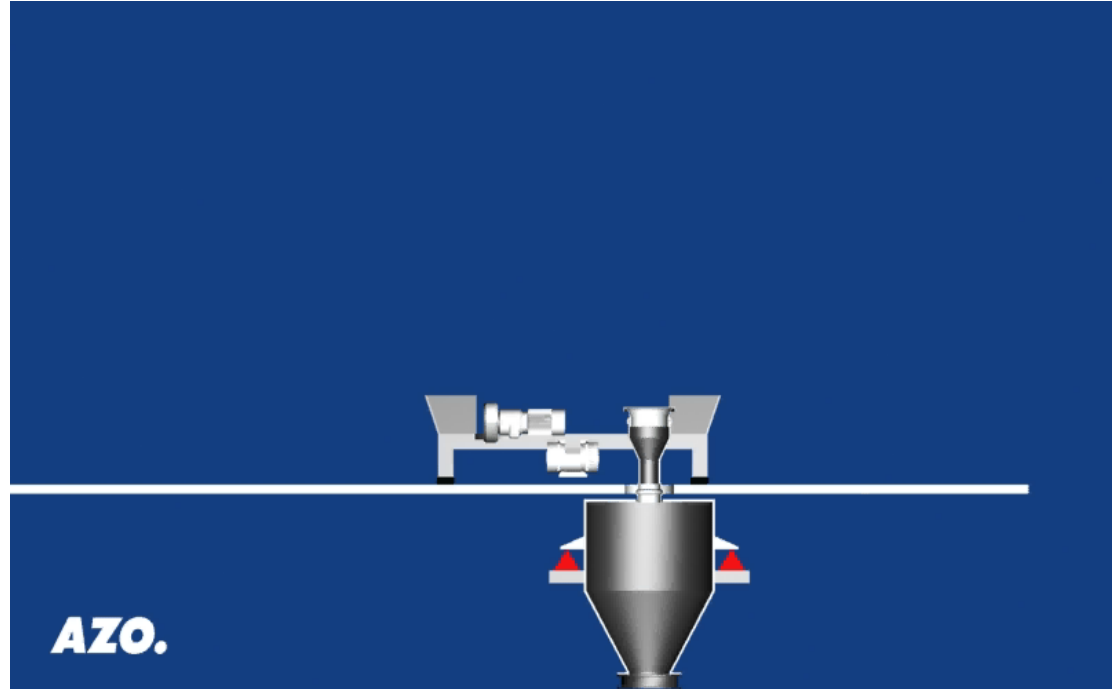

Unit for filling of DOSITAINER® with product out of sacks

## AZO Componenter

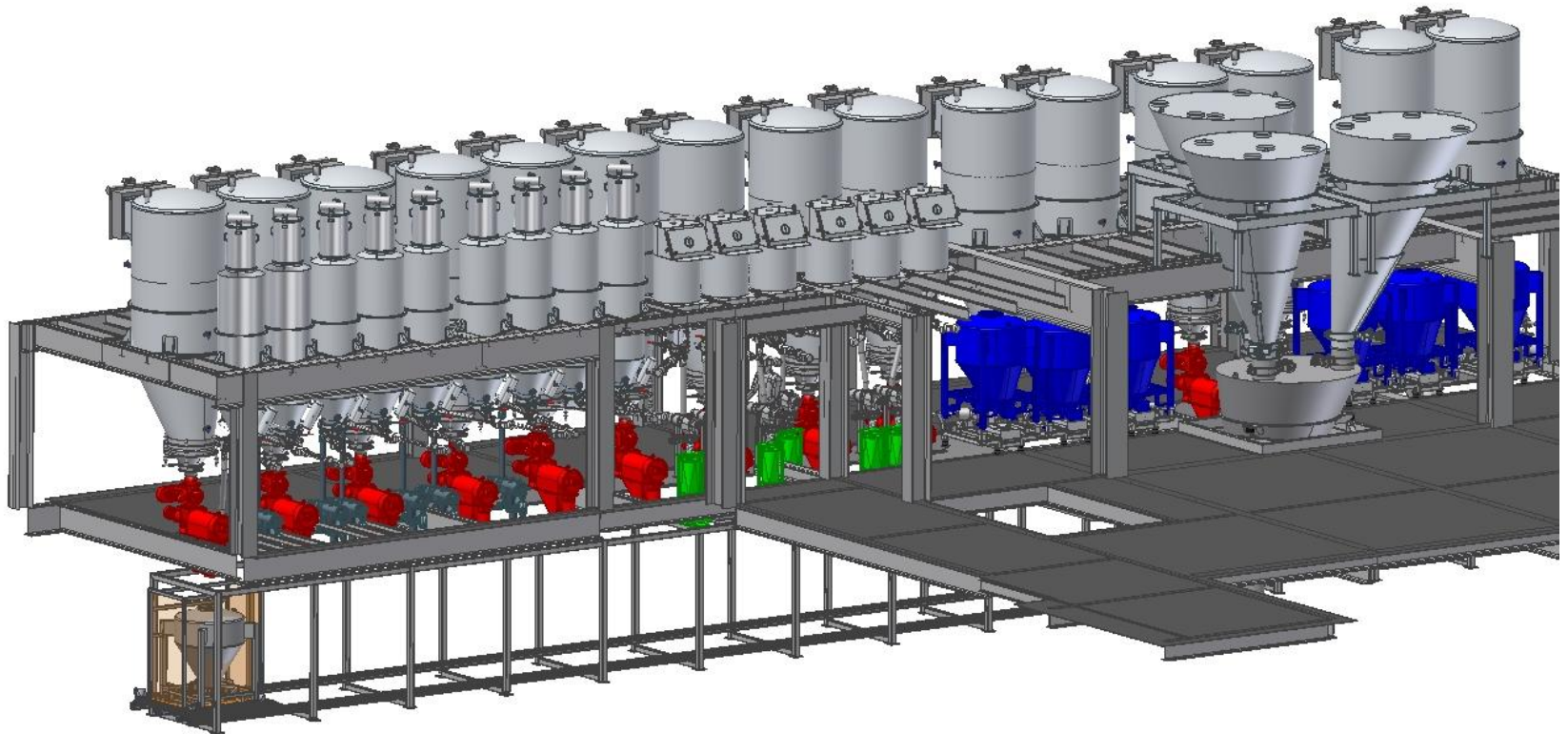



Automation for micro ingredients



Container on travelling scale for collecting and weighing of the components

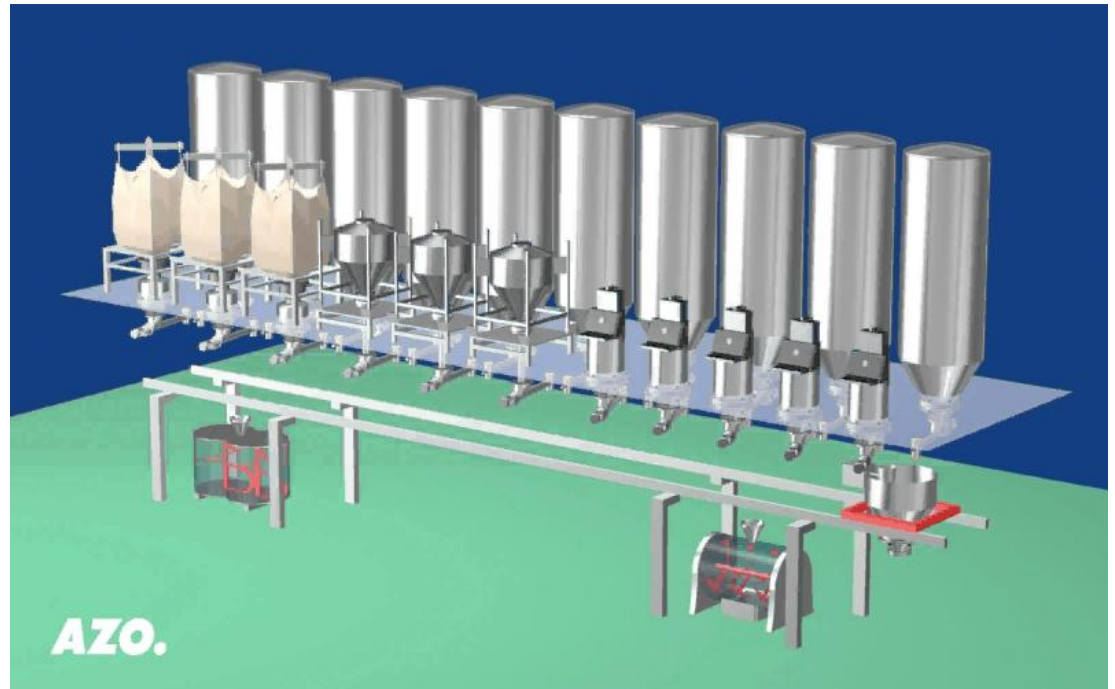

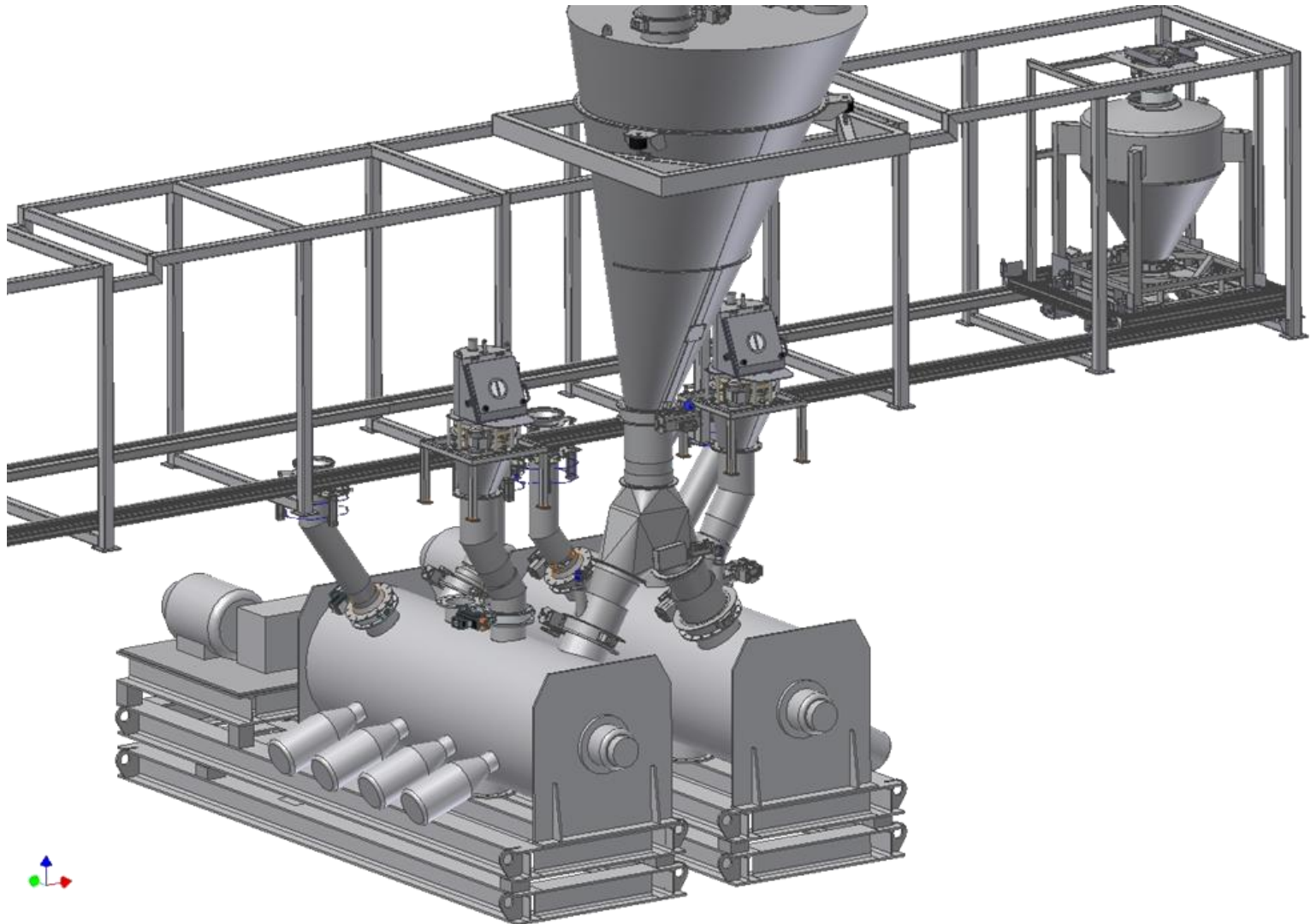

Mixer feeding



Feeding hopper for manual feeding directly into the mixer

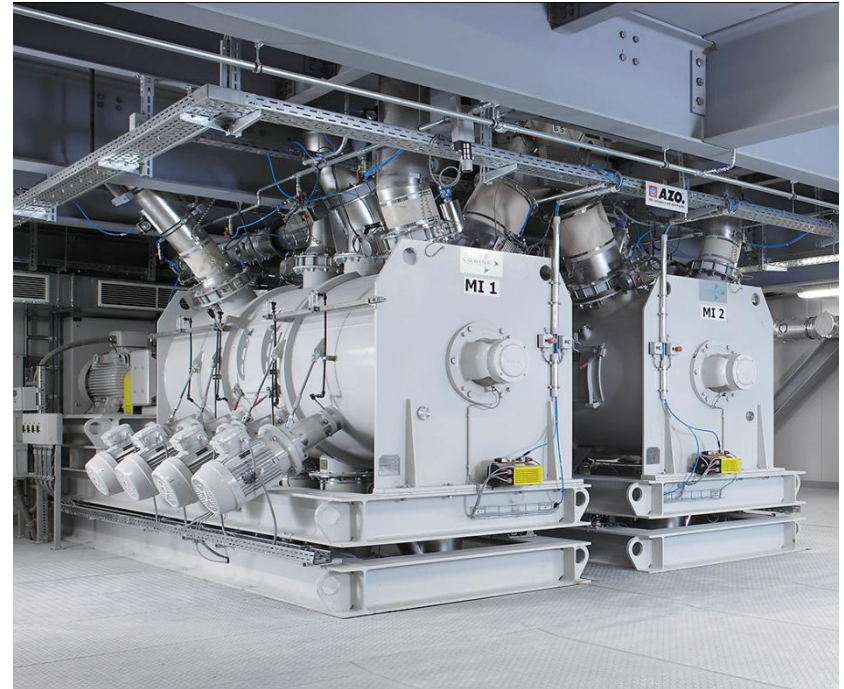



Filling of product in container, big bags, sacks



Container and big bag filling station



Packing of finished product in sacks

Central process leading and visualisation system



Control centre for operating and monitoring



Operation panel in the production area

- Pneumatic conveying systems
  - Big bag filling systems
  - Big bag discharge systems
  - Screening systems
  - Silo and discharge systems
  - Minor ingredient automation systems
- Container systems, Containment
- Liquid weighing system
- Turnkey/ Customised solutions from a single supplier
  - Engineering
  - Equipment
  - Process IT
  - Installation, Supervision, Commissioning and After Sales
- Future-proof quality “Made in Germany”
- Service throughout the world





